

8

7

6

5

4

3

2

1

### REVISIONS

EFFECTIVITY	REV	DESCRIPTION	DATE	APPROVED
FUTURE	A	FIRST RELEASE ISSUE	4 / 10 / 09	
FUTURE	B	ADDED GRAIN SPACER O-RINGS	11 / 11 / 09	

### NOTES:

- MOTOR ASSEMBLY SHOWN WITH SPECIFIED MOTOR HARDWARE & RELOAD KIT.

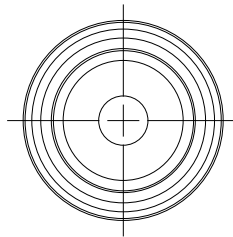
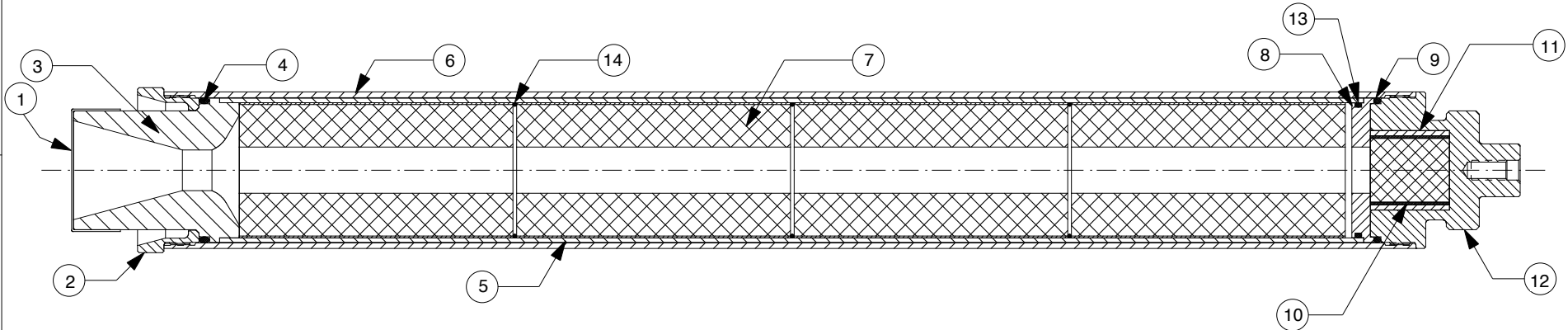

VIEW AFT CLOSURE

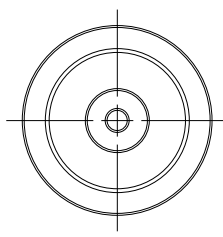

VIEW FORWARD CLOSURE

3	00036	GRAIN SPACER O-RINGS (2-1/2" X 1/16")	036	14
1	00142	FORWARD SEAL DISK O-RING		13
1	75FCP	FORWARD CLOSURE (PLUGGED)		12
1	03080	SMOKE CHG INSULATOR (1.5" O.D. X 1.5")		11
1	03287	SMOKE CHARGE (1.305" O.D. X 1.5")		10
1	00230	FORWARD O-RING (2.75" O.D. X 1/8")	230	9
1	75FSD	FORWARD SEAL DISK		8
4	03616-6	PROPELLANT GRAINS (2.557" O.D. X 5.188")		7
1	7551C	CASE		6
1	03035-4	PHENOLIC LINER (2.727" O.D. X 21.688")		5
1	00230	AFT O-RING (2.75" O.D. X 1/8")	230	4
1	01770-1	HP 75MM NOZZLE (.769" DT DRILLED)		3
1	75ACC	AFT CLOSURE		2
1	04214	NOZZLE CAP (2.25" I.D.)		1

QTY	PART NUMBER	DESCRIPTION	ITEM
LIST OF MATERIAL			
CONTRACT NUMBER		 2113 W. 850 N. Street Cedar City, Utah 84720 (435) 865-7100 (Ph) (435) 865-7120 (Fax)	
PREP	G. ROSENFELD		
CHKR			
APVD		SIZE	NUMBER
APVD		<b>A</b>	<b>ASSY DWG</b>
SCALE 1 / 3		SHEET 1 OF 1	

### SUPPLIER DATA

AEROTECH DIV RCS RMC INC

### RELOAD KIT IDENTIFICATION

13180P

M1780NT-P

UNLESS OTHERWISE SPECIFIED DIMENSIONS ARE IN INCHES

.XX +/- .010	.XXX +/- .005	ANGLES +/- 2 deg.
-----------------	------------------	----------------------

MATERIAL

NOTED

FINISH

PART NUMBER

DESCRIPTION

8

7

6

5

4

3

2

1