

Before You Begin

- Do not modify the motor in any way.
- If any parts are missing or damaged, call AeroTech at 435-865-7100.
- Use only AeroTech RMS reload kits to refurbish an RMS motor.
- Do not interchange parts from different reload kits.
- Do not reuse any parts of the RMS reload kit.
- Save the reload kit plastic bag for the used reload kit parts. Dispose of bag and parts properly.

Hardware and Supplies Required

RMS 54mm aft closure
RMS 54/2800 case
54mm forward seal disk
54mm standard forward closure
-or-
54mm reload adapter system (also refer to RAS instructions)
Synco™ Super Lube™ or other grease
Hobby knife
Wet wipes or damp paper towels

Preparation for Flight

1. Insert the coated end of a FirstFire™, Firestar™ or other initiator through the nozzle throat until it stops against the smoke charge grain.
2. Secure the initiator to the nozzle with a piece of masking tape.
3. Install the motor into the rocket's motor mount tube. Ensure that the motor is securely retained in the rocket by using positive mechanical means to prevent it from being ejected during recovery system deployment.
4. Prepare the rocket's recovery system and then launch the rocket in accordance with the Tripoli Rocketry Association (TRA) Safety Code and National Fire Protection Association (NFPA) Code 1127.

Post-Recovery Cleanup

NOTE: Perform motor clean-up as soon as possible after motor firing. Propellant and smoke charge residues become difficult to remove after 24 hours and can lead to corrosion of the metal parts. Place the spent motor components in the reload kit plastic bag and dispose of properly.

1. After the motor has cooled down, unthread and remove the forward and aft closures.
2. Remove the delay charge assembly components from the forward closure and discard. Using wet wipes or damp paper towels, remove all delay charge and propellant residue from the closures.

Post-Recovery Cleanup (cont'd)

3. Remove and discard the forward and aft o-rings from the motor case. Remove the liner, forward seal disk and nozzle from the casing by pushing on the nozzle end. Remove the forward seal disk from the liner, and remove and discard the forward seal disk o-ring. **DO NOT DISCARD THE FORWARD SEAL DISK!** Discard the nozzle and liner. Using wet wipes or damp paper towels, wipe the inside of the casing and the forward seal disk to remove all propellant residue.

4. Apply a light coat of grease to all threads and the inside of the motor case. Reassemble metal parts and store motor in a dry place.

First Aid

For a minor burn, apply a burn ointment. For a severe burn, immerse the burned area in ice water at once and see a physician as quickly as possible. In the unlikely event of oral ingestion of the propellant, induce vomiting and see a physician as quickly as possible. Metalstorm composite propellant consists primarily of Ammonium Perchlorate and a rubber-like plastic elastomer.

Disposal

Damaged or defective reload kits should be returned to RCS.

Fire Safety

Tests show that the pyrotechnic components of RMS™ reload kits will not explode in fires and normally will not ignite unless subjected to direct flame and then will burn slowly. Use water to fight any fires in which AeroTech RMS™ reload kit pyrotechnic components may become involved: Direct the water at the AeroTech RMS™ reload kit pyrotechnic components to keep them below their 550 deg. F autoignition temperature. Foam and carbon dioxide fire extinguishers will NOT extinguish burning propellants of the type used in RMS™ reload kit pyrotechnic components. Keep reload kit pyrotechnic components away from flames, sources of heat and flammable materials.

Disclaimer and Warranty

NOTICE: As we cannot control the storage and use of our products, once sold we cannot assume any responsibility for product storage, transportation or usage. RCS shall not be held responsible for any personal injury or property damage resulting from the handling, storage or use of our product. The buyer assumes all risks and liabilities therefrom and accepts and uses AeroTech/RCS products on these conditions. No warranty either expressed or implied is made regarding AeroTech/RCS products, except for replacement or repair, at RCS's option, of those products which are proven to be defective in manufacture within one year from the date of original purchase. For repair or replacement under this warranty, please contact RCS. Proof of purchase will be required. Note: Your state may provide additional rights not covered by this warranty.



HIGH-POWER RMS™ Reloadable Motor System™

L1090W-PS Rocket Motor Reload Kit For RMS-54/2800 Motor Hardware White Lightning™ Composite Propellant

NOTE: This reload kit does not include an ejection charge. L1090W-PS motors must be used in conjunction with a timer, altimeter or radio-actuated recovery system.

Do not open reload kit until ready to use.

WARNING-FLAMMABLE: Read Instructions Before Use. Use RMS reload kits only in accordance with instructions. Sale to persons under 18 years of age prohibited by federal law. For use only by certified users 18 years of age or older. Ignite by electrical means only. Do not smoke when loading RMS motors or use in the vicinity of open flames. **CAUTION:** Keep out of reach of children. Follow NAR & TRA safety codes at all times. Motor hot after firing.

Certified by the Tripoli Rocketry Association • Made in U.S.A. • www.aerotech-rocketry.com
AeroTech Division, RCS Rocket Motor Components, Inc., 2113 W. 850 N. St., Cedar City, UT 84721

L1090W-PS Typical Time-Thrust Curve

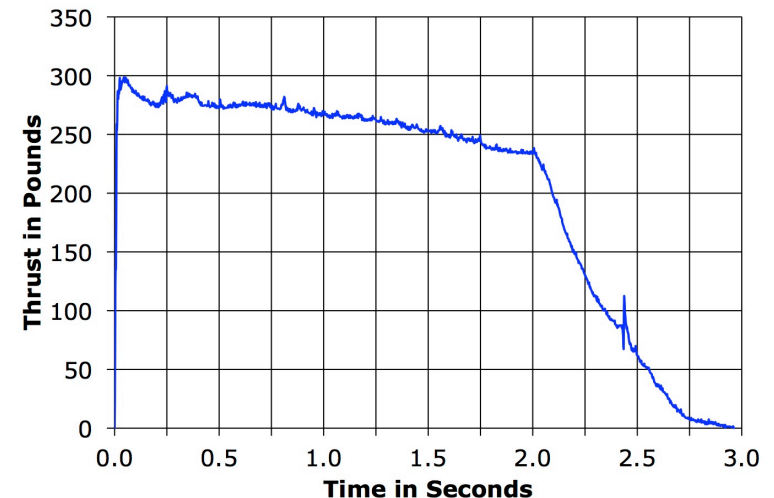

Motor Specifications

Total Impulse:	2,736 N-sec	Burn Time:	2.5 seconds
Propellant Wt.:	1,400 grams	Peak Thrust:	300 pounds
Loaded Wt.:	2,370 grams	Delay Time:	Plugged
Motor Diameter:	54mm	Motor Length:	24.68"

L1090W-PS Assembly Drawing and Instructions

NOTE: THE DRAWING SHOWN BELOW IS A GENERIC REPRESENTATION OF THE ACTUAL MOTOR. NOZZLE SIZE, NUMBER AND SIZE OF PROPELLANT GRAINS AND LENGTH OF SMOKE GRAIN & SPACER MAY BE DIFFERENT. FOR A DETAILED ASSEMBLY DRAWING OF THIS MOTOR PLEASE VISIT THE AEROTECH WEBSITE AT WWW.AEROTECH-ROCKETRY.COM

ITEM	DESCRIPTION	QTY
1	NOZZLE CAP (NOT SHOWN)	1
2	AFT CLOSURE	1
3	NOZZLE	1
4	AFT O-RING	1
5	LINER	1
6	CASE	1
7	PROPELLANT GRAINS	5
8	FORWARD SEAL DISK	1
9	FORWARD O-RING	1
10	AFT SMOKE GRAIN SPACER	1
11	SMOKE GRAIN	1
12	SMOKE GRAIN INSULATOR	1
13	FORWARD CLOSURE (STD)	1
14	EJECTION CHARGE	NONE
15	EJECTION CHARGE CAP	1
16	FWD SMOKE GRAIN SPACER	1
17	SMOKE GRAIN O-RING	1
18	FORWARD SEAL DISC O-RING	1
19	GRAIN SPACER O-RINGS	4

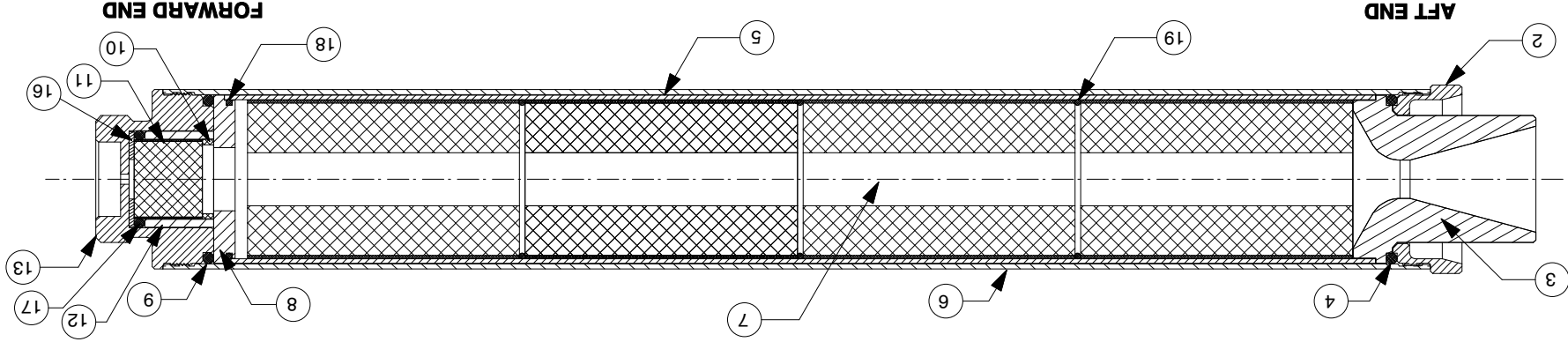

Assembly Instructions

(numbers refer to item numbers on drawing):

1. Lightly grease o-rings (4, 9, 17 & 18), case threads (6) and delay cavity of forward closure (13) and forward end of smoke grain (11).
2. Assemble smoke grain (11), smoke grain spacer (10), smoke grain insulator (12) and smoke grain o-ring (17) as shown.
3. Install forward delay spacer (16) into forward closure (13), then push step 2 smoke grain assembly into forward closure (13), o-ring end first.
4. Install forward seal disk o-ring (18) on groove in forward seal disk (8) and insert this assembly into one end of liner (5) until seated.
5. Insert propellant grains (7) into liner (5) with a grain spacer o-ring (19) between each one, then push liner assembly into case (6) until recessed equally from ends of case.
6. Install forward o-ring (9) into (forward) end of case (6) with the forward seal disk (8)
7. Thread forward closure (13) into the (forward) end of the case (6) with the forward o-ring (9) until seated.
8. Assemble nozzle (3), aft o-ring (4), and aft closure (2) into open (aft) end of case (6) until seated.

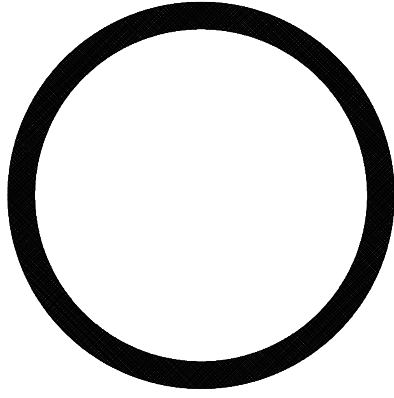

Forward & Aft O-rings (4 & 9)
2" x 1/8" 2224

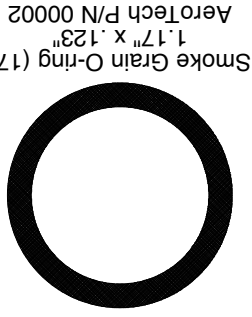

Smoke Grain O-ring (17)
1.17" x .123"
AeroTech P/N 00002

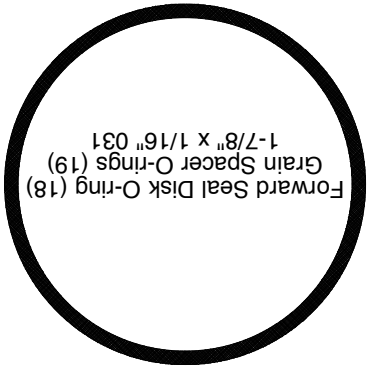

Forward Seal Disk O-ring (18)
1-7/8" x 1/16" 031

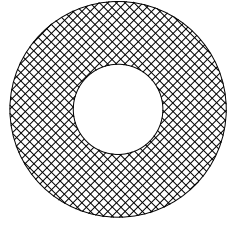

Forward Smoke Grain
Spacer (16)