

8

7

6

5

4

3

2

1

REVISIONS

EFFECTIVITY	REV	DESCRIPTION	DATE	APPROVED
FUTURE	A	FIRST RELEASE ISSUE	12 / 10 / 19	

NOTES:

- MOTOR ASSEMBLY SHOWN WITH SPECIFIED MOTOR HARDWARE & RELOAD KIT.

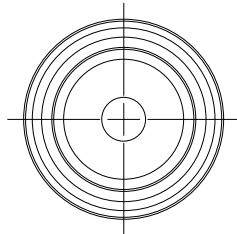
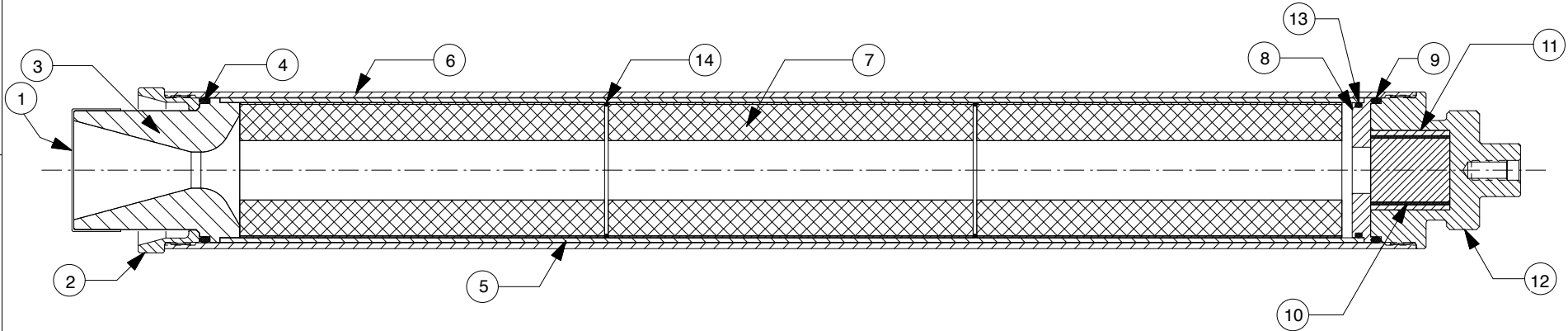

VIEW AFT CLOSURE

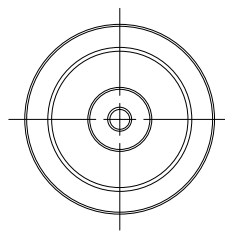

VIEW FORWARD CLOSURE

2	00036	GRAIN SPACER O-RINGS (2-1/2" X 1/16")	036	14
1	00142	FORWARD SEAL DISK O-RING		13
1	75FCP	FORWARD CLOSURE (PLUGGED)		12
1	03080	SMOKE CHG INSULATOR (1.5" O.D. X 1.5")		11
1	03287	SMOKE CHARGE(1.305" O.D. X 1.5")		10
1	00230	FORWARD O-RING (2.75" O.D. X 1/8")	230	9
1	75FSDSS	FORWARD SEAL DISK		8
3	03X75-1	PROP GRAINS (2.557" O.D. X 6.917" X 1.125" CORE)		7
1	7551C	CASE		6
1	03035-4	PHENOLIC LINER (2.727" O.D. X 21.688")		5
1	00230	AFT O-RING (2.75" O.D. X 1/8")	230	4
1	01770	HP 75MM NOZZLE (.685" DT UNDRILLED)		3
1	75ACC	AFT CLOSURE		2
1	04214	NOZZLE CAP (2.25" I.D.)		1

QTY	PART NUMBER	DESCRIPTION	ITEM
LIST OF MATERIAL			
CONTRACT NUMBER		 2113 W. 850 N. Street Cedar City, Utah 84720 (435) 865-7100 (Ph) (435) 865-7120 (Fax)	
PREP	G. ROSENFELD		
CHKR		HP 75/5120 MOTOR WITH M2050X-P RELOAD KIT	
APVD			
APVD		SIZE	NUMBER
		A	ASSY DWG
		SCALE	1 / 3
		SHEET 1 OF 1	

SUPPLIER DATA		RELOAD KIT IDENTIFICATION		UNLESS OTHERWISE SPECIFIED DIMENSIONS ARE IN INCHES		
AEROTECH DIV. RCS RMC INC.	13205P	M2050X-PS		.XX +/- .010	.XXX +/- .005	ANGLES +/- 2 deg.
				MATERIAL		
				NOTED		
				FINISH		
	PART NUMBER	DESCRIPTION				

8

7

6

5

4

3

2

1